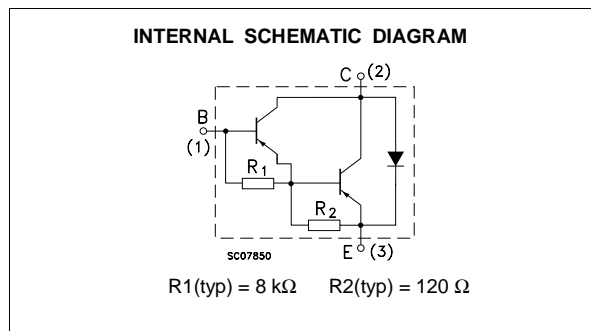
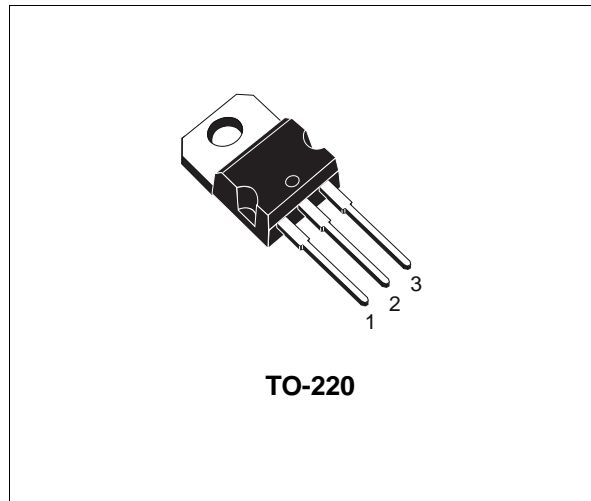

SILICON PNP POWER DARLINGTON TRANSISTOR

- STMicroelectronics PREFERRED SALESTYPE
- PNP DARLINGTON
- INTEGRATED ANTIPARALLEL COLLECTOR-EMITTER DIODE

APPLICATIONS:

- GENERAL PURPOSE SWITCHING
- GENERAL PURPOSE SWITCHING AND AMPLIFIER

ABSOLUTE MAXIMUM RATINGS

Symbol	Parameter	Value	Unit
V_{CBO}	Collector-Base Voltage ($I_E = 0$)	80	V
V_{CEO}	Collector-Emitter Voltage ($I_B = 0$)	80	V
V_{EBO}	Emitter-Base Voltage ($I_C = 0$)	5	V
I_C	Collector Current	10	A
I_{CM}	Collector Peak Current	15	A
I_B	Base Current	250	mA
P_{tot}	Total Dissipation at $T_C \leq 25^\circ\text{C}$	65	W
T_{stg}	Storage Temperature	-65 to 150	$^\circ\text{C}$
T_j	Max. Operating Junction Temperature	150	$^\circ\text{C}$

For PNP type voltage and current values are negative.

THERMAL DATA

R _{thj-case}	Thermal Resistance Junction-case	Max	1.92	°C/W
R _{thj-amb}	Thermal Resistance Junction-ambient	Max	62.5	°C/W

ELECTRICAL CHARACTERISTICS (T_{case} = 25 °C unless otherwise specified)

Symbol	Parameter	Test Conditions	Min.	Typ.	Max.	Unit
I _{CEO}	Collector Cut-off Current (I _B = 0)	V _{CE} = 80 V			1	mA
I _{EBO}	Emitter Cut-off Current (I _C = 0)	V _{EB} = 5 V			5	mA
I _{CEV}	Collector Cut-off Current (V _{EB} = -1.5V)	V _{CE} = 80 V			300	μA
V _{CEO(sus)} *	Collector-Emitter Sustaining Voltage (I _B =0)	I _C = 200 mA	80			V
V _{CE(sat)} *	Collector-Emitter Saturation Voltage	I _C = 5 A I _B = 0.01 A			2	V
		I _C = 10 A I _B = 0.1 A			3	V
V _{BE(sat)} *	Base-Emitter Saturation Voltage	I _C = 5 A I _B = 0.01 A			2.8	V
		I _C = 10 A I _B = 0.1 A			4.5	V
h _{FE} *	DC Current Gain	I _C = 5 A V _{CE} = 3 V	1000		20000	
		I _C = 10 A V _{CE} = 3 V	100			

* Pulsed: Pulse duration = 300 μs, duty cycle 1.5 %
For PNP type voltage and current values are negative.

TO-220 MECHANICAL DATA

DIM.	mm			inch		
	MIN.	TYP.	MAX.	MIN.	TYP.	MAX.
A	4.40		4.60	0.173		0.181
C	1.23		1.32	0.048		0.051
D	2.40		2.72	0.094		0.107
D1		1.27			0.050	
E	0.49		0.70	0.019		0.027
F	0.61		0.88	0.024		0.034
F1	1.14		1.70	0.044		0.067
F2	1.14		1.70	0.044		0.067
G	4.95		5.15	0.194		0.203
G1	2.4		2.7	0.094		0.106
H2	10.0		10.40	0.393		0.409
L2		16.4			0.645	
L4	13.0		14.0	0.511		0.551
L5	2.65		2.95	0.104		0.116
L6	15.25		15.75	0.600		0.620
L7	6.2		6.6	0.244		0.260
L9	3.5		3.93	0.137		0.154
DIA.	3.75		3.85	0.147		0.151

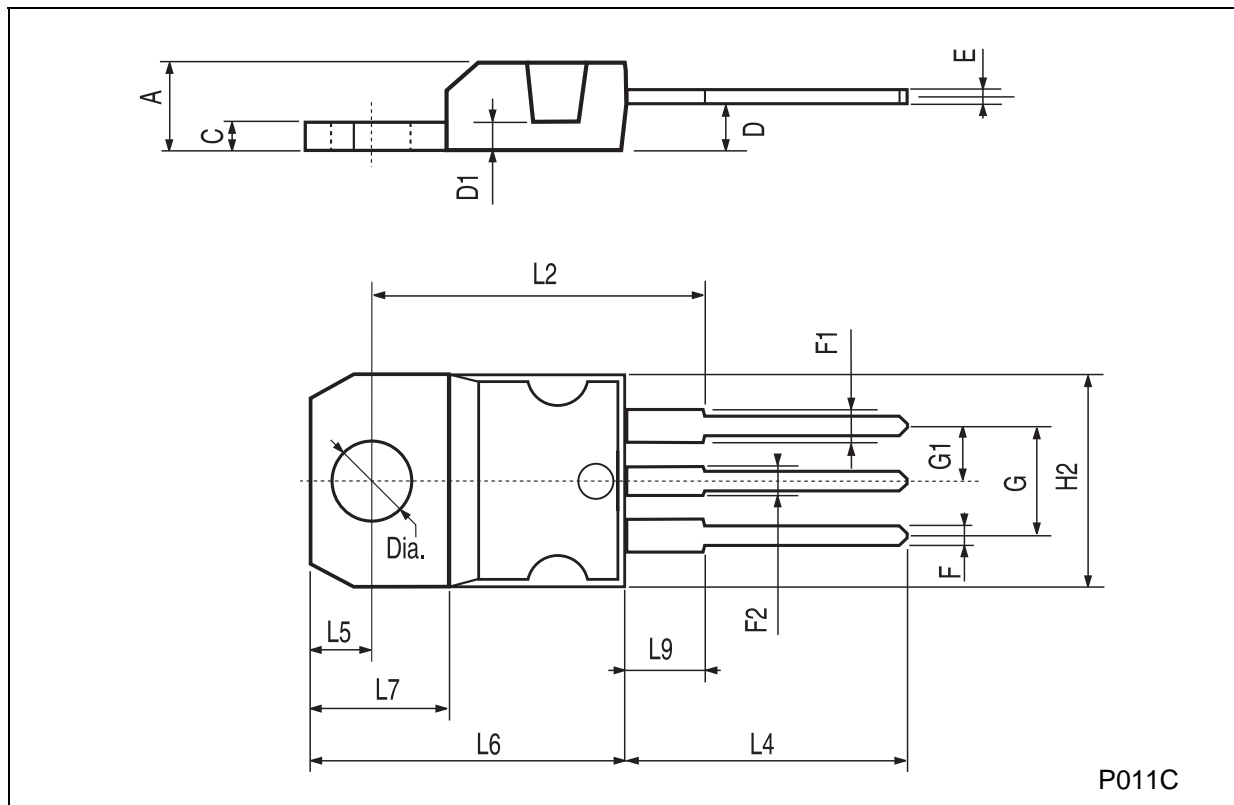

Information furnished is believed to be accurate and reliable. However, STMicroelectronics assumes no responsibility for the consequences of use of such information nor for any infringement of patents or other rights of third parties which may result from its use. No license is granted by implication or otherwise under any patent or patent rights of STMicroelectronics. Specification mentioned in this publication are subject to change without notice. This publication supersedes and replaces all information previously supplied. STMicroelectronics products are not authorized for use as critical components in life support devices or systems without express written approval of STMicroelectronics.

The ST logo is a trademark of STMicroelectronics

© 2000 STMicroelectronics – Printed in Italy – All Rights Reserved

STMicroelectronics GROUP OF COMPANIES

Australia - Brazil - China - Finland - France - Germany - Hong Kong - India - Italy - Japan - Malaysia - Malta - Morocco - Singapore - Spain - Sweden - Switzerland - United Kingdom - U.S.A.

<http://www.st.com>

This datasheet has been download from:

www.datasheetcatalog.com

Datasheets for electronics components.